

# MILLING AND DRILLING HEAD

Sub Tool Post -End Surface Machining

# GROMAX

TYPE

CITIZEN

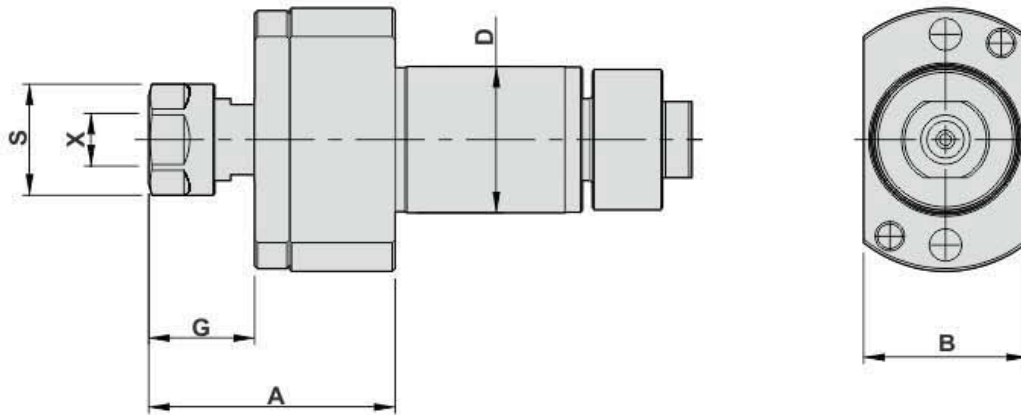

- To be used for collet DIN 6499
- Collet is not included

## DIMENSIONS

Models	D	X Capacity	S	Maximum R.P.M.	A	B	G	Code No.	Order No.	(Kg) Weight
L20E/7M9	25	1-7 ER11	19	6000	42	28	18	125603-000	GSE-3307	0.4
L20E/X/XII	25	1-7 ER11	19	6000	77	28	18.5	125607-000	GSE-3407	0.7

# MILLING AND DRILLING HEAD OFFSET

Sub Tool Post -Radius Machining

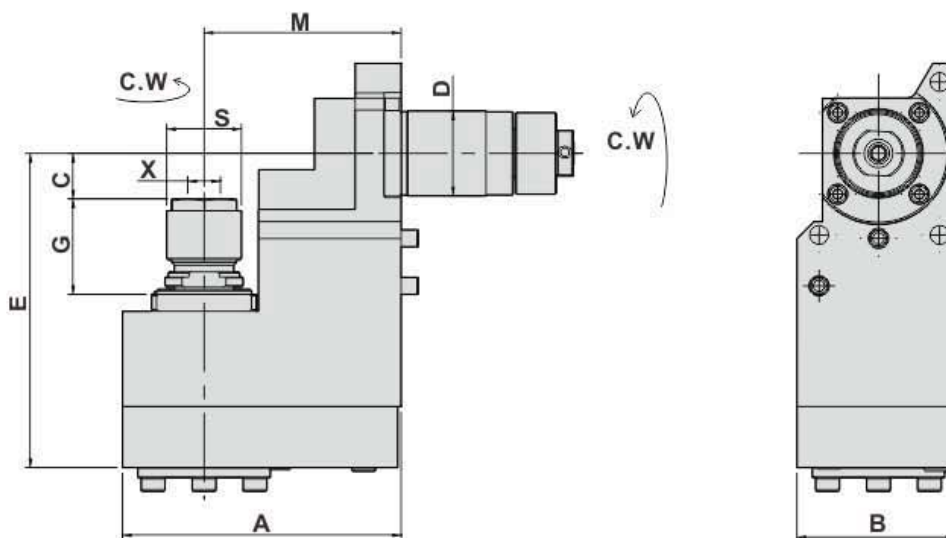

- To be used for collet DIN 6499
- Collet is not included

i=2:1 減速

## DIMENSIONS

Models	D	X Capacity	S	Maximum R.P.M.	A	B	C	E	G	M	Code No.	Order No.	(Kg) Weight
L20E/7M9	25	1-10 ER16M	22	4000	82	46.5	13	92.5	28	58	225602-000	GSS-1330	2.2

## AXIAL MILLING AND DRILLING HEAD

Main Tool Post - Radius Machining

TYPE

CITIZEN

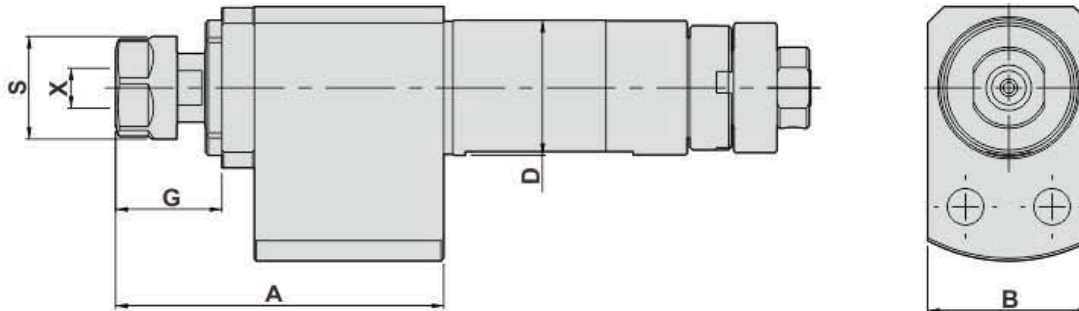

- To be used for collet DIN 6499
- Collet is not included

### DIMENSIONS

Models	D	X Capacity	S	Maximum R.P.M.	A	B	G	Code No.	Order No.	(Kg) Weight
L20E	25	1-7 ER11	19	6000	60.7	30	19.7	125602-000	GSC-907	0.5

## MILLING AND DRILLING HEAD OFFSET

Sub Tool Post - Radius Machining

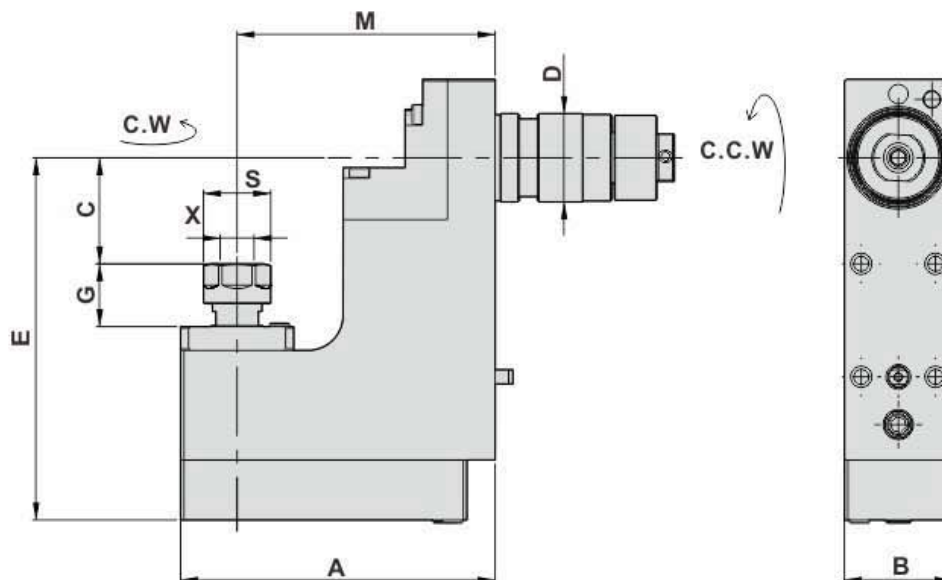

- To be used for collet DIN 6499
- Collet is not included

### DIMENSIONS

Models	D	X Capacity	S	Maximum R.P.M.	A	B	C	E	G	M	Code No.	Order No.	(Kg) Weight
L20E/L20XII/ L32	25	1-7 ER11	19	4000	89	30.5	30	102	18	73	225606-000	GSC-1507	1.7

# MILLING AND DRILLING HEAD

Main Tool Post -Radius Machining

# GROMAX

TYPE CITIZEN

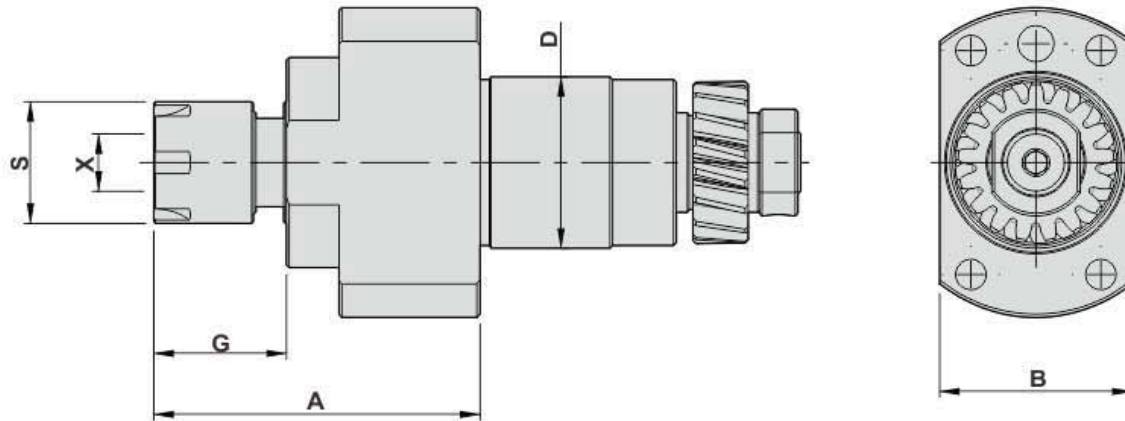

- To be used for collet DIN 6499
- Collet is not included

## DIMENSIONS

Models	D	X Capacity	S	Maximum R.P.M.	A	B	G	Code No.	Order No.	(Kg) Weight
L20E(1M)/L20IX/L9	31	1-10 ER16M	22	6000	59	35	24	131701-000	GSC-1210	0.7

# MILLING AND DRILLING HEAD DOUBLE HEADS-OFFSET

Main Tool Post -Radius Machining

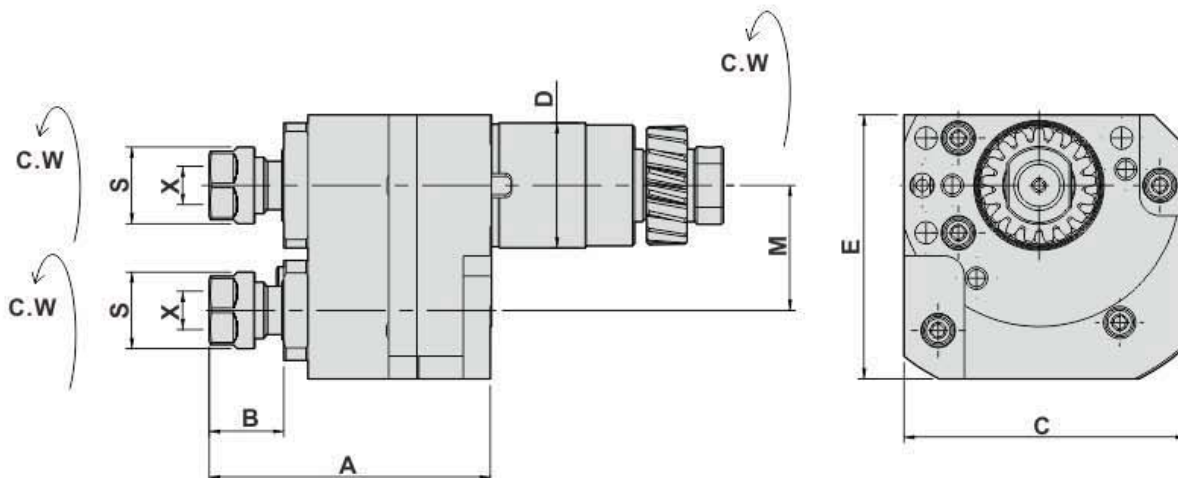

- To be used for collet DIN 6499
- Collet is not included

## DIMENSIONS

Models	D	X Capacity	S	Maximum R.P.M.	A	B	C	E	M	Code No.	Order No.	(Kg) Weight
L20E(1M)/7M9/L20	31	1-7 ER11	19	4000	70	18.5	70	65.5	31	131702-000	GSC-1307	1.6

## MILLING AND DRILLING HEAD MULTI HEADS-OFFSET

Main Tool Post -End Surface Machining

TYPE CITIZEN

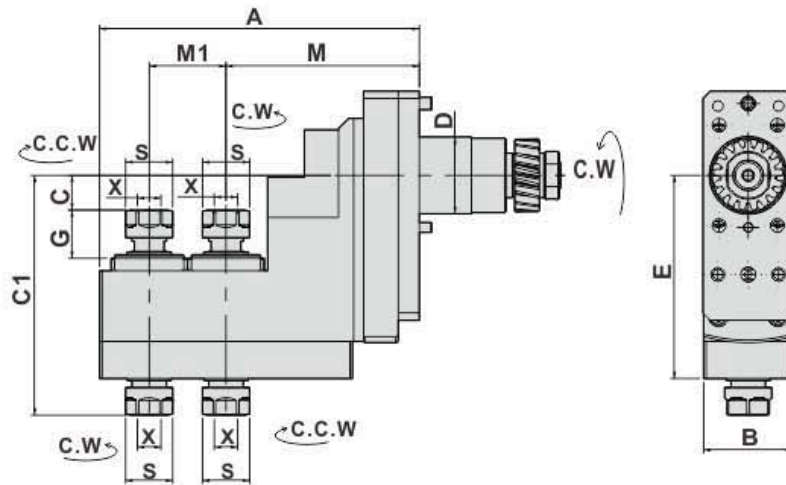

- To be used for collet DIN 6499
- Collet is not included

### DIMENSIONS

Models	D	X Capacity	S	Maximum R.P.M	A	B	C	C1	E	G	M	M1	Code No.	Order No.	(Kg) Weight
L20/L20E (1M)/7M9	31	1-7 ER11	19	4000	129	36	14	97	82	19	78	31	231701-000	GSE-3107	2.6

## MILLING AND DRILLING HEAD MULTI HEADS-OFFSET

Main Tool Post -End Surface Machining

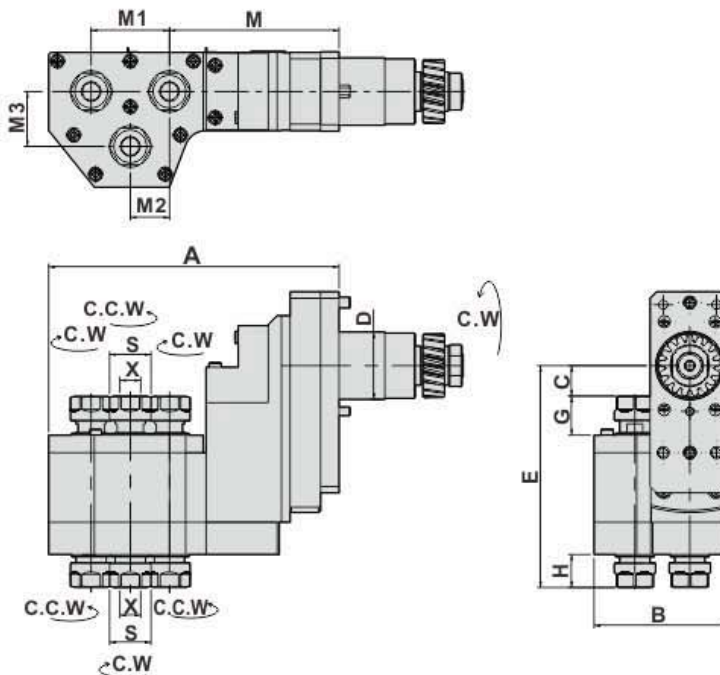

- To be used for collet DIN 6499
- Collet is not included

### DIMENSIONS

Models	D	X Capacity	S	Maximum R.P.M	A	B	C	E	H	G	M	M1	M2	M3	Code No.	Order No.	(Kg) Weight
L20/L20E (1M)/7M9	31	1-7 ER11	19	4000	134	62	14	102	14.5	18	78	36	18	25.24	231703-000	GSE-3207	3.4



## MILLING AND DRILLING HEAD MULTI HEADS-OFFSET

Main Tool Post -End Surface Machining

TYPE CITIZEN

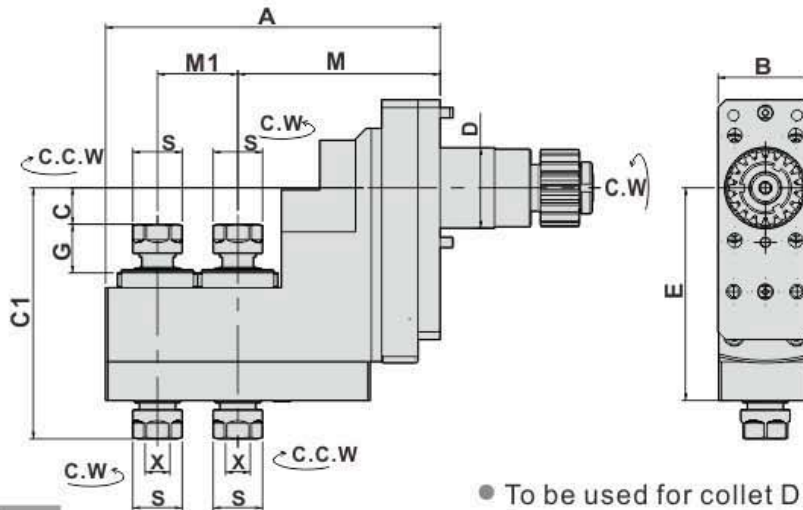

- To be used for collet DIN 6499
- Collet is not included

### DIMENSIONS

Models	D	X Capacity	S	Maximum R.P.M	A	B	C	C1	E	G	M	M1	Code No.	Order No.	(Kg) Weight
L20E (2M) /L32	31	1-7 ER11	19	4000	129	36	14	97	82	19	78	31	231618-000	GSE-3707	2.6

## MILLING AND DRILLING HEAD MULTI HEADS-OFFSET

Main Tool Post -End Surface Machining

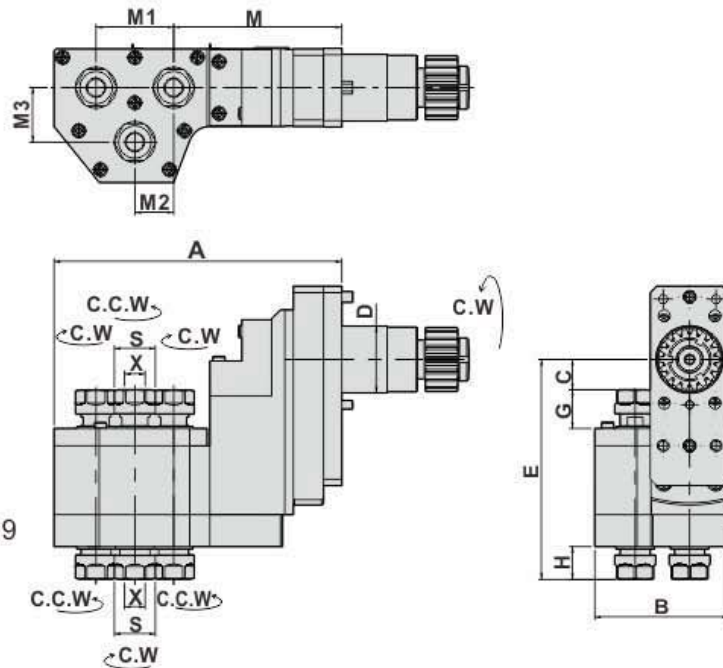

- To be used for collet DIN 6499
- Collet is not included

### DIMENSIONS

Models	D	X Capacity	S	Maximum R.P.M	A	B	C	E	H	G	M	M1	M2	M3	Code No.	Order No.	(Kg) Weight
L20E (2M) /L32	31	1-7 ER11	19	4000	134	62	14	102	14.5	18	78	36	18	25.24	231619-000	GSE-3807	3.4



## MILLING AND DRILLING HEAD

Main Tool Post -Radius Machining

TYPE

CITIZEN

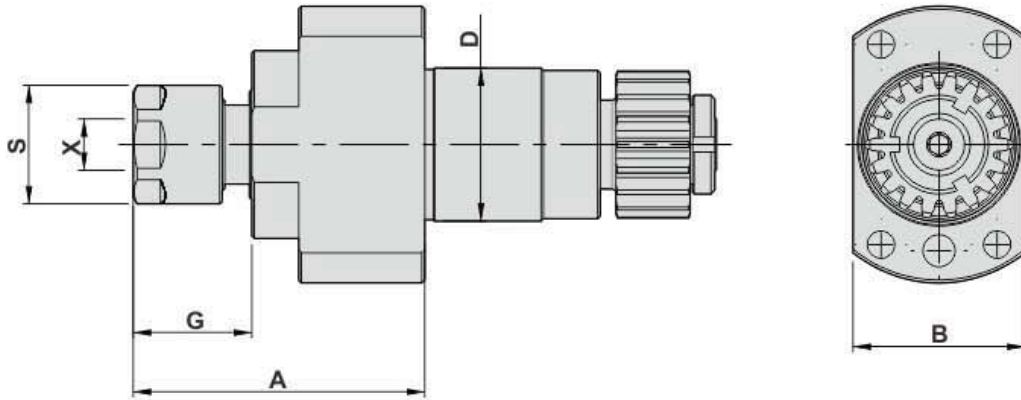

- To be used for collet DIN 6499
- Collet is not included

### DIMENSIONS

Models	D	X Capacity	S	Maximum R.P.M.	A	B	G	Code No.	Order No.	(Kg) Weight
L20E(2M) / L32/A20	31	1-10 ER16M	24	6000	59	35	24	131606-000	GSC-1310	0.7

## MILLING AND DRILLING HEAD MULTI HEADS-OFFSET

Main Tool Post -End Surface Machining

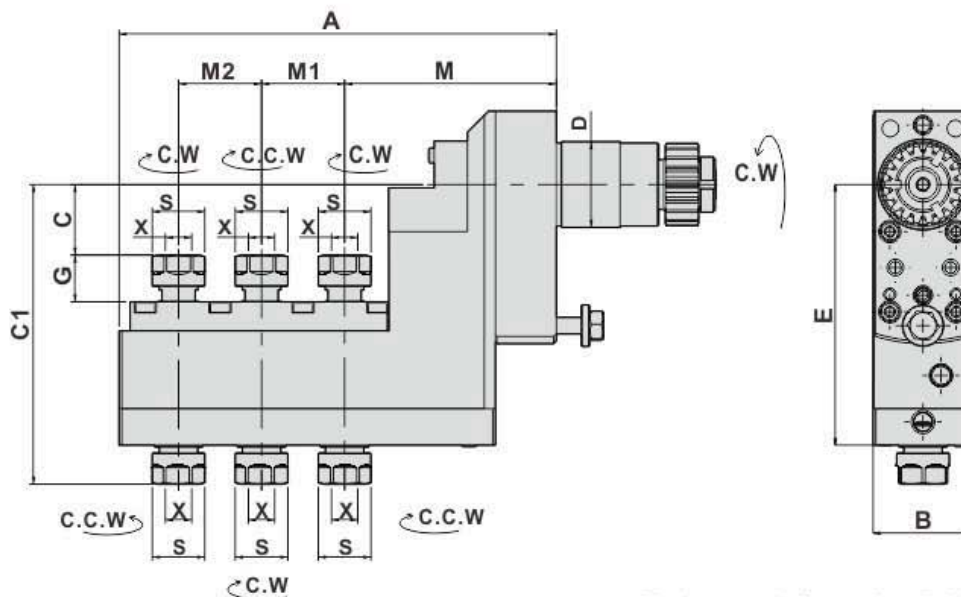

- To be used for collet DIN 6499
- Collet is not included

### DIMENSIONS

Models	D	X Capacity	S	Maximum R.P.M.	A	B	C	C1	E	G	M	M1/ M2	Code No.	Order No.	(Kg) Weight
L20E (2M) /L32/A20	31	1-7 ER11	19	4000	158	36	25.5	108.3	94.2	17	76.5	30	231616-000	BSE-707	3



# MILLING AND DRILLING HEAD MULTI HEADS-OFFSET

Main Tool Post -Radius Machining  
Main Tool Post -End Surface Machining



TYPE CITIZEN

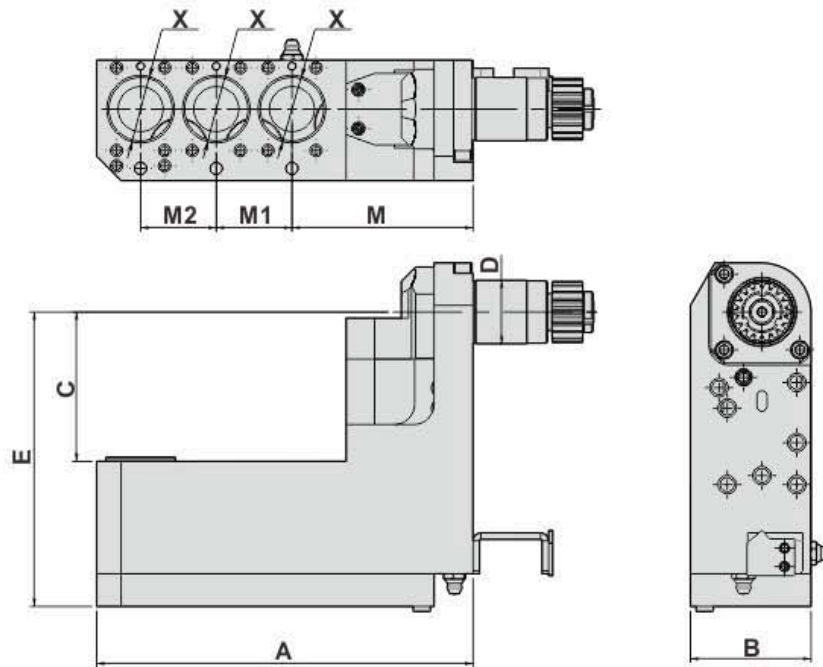

- To be used for collet DIN 6499
- Collet is not included

## DIMENSIONS

Models	D	X Capacity	Maximum R.P.M	A	B	C	E	M	M1/M2	Code No.	Order No.	(Kg) Weight
L20E (2M) /L32	31	31	4000	184	59	73	144	88.5	37	231623-000	GSE-3210	6.5

# MILLING AND DRILLING HEAD DOUBLE HEADS-OFFSET

Main Tool Post -Radius Machining

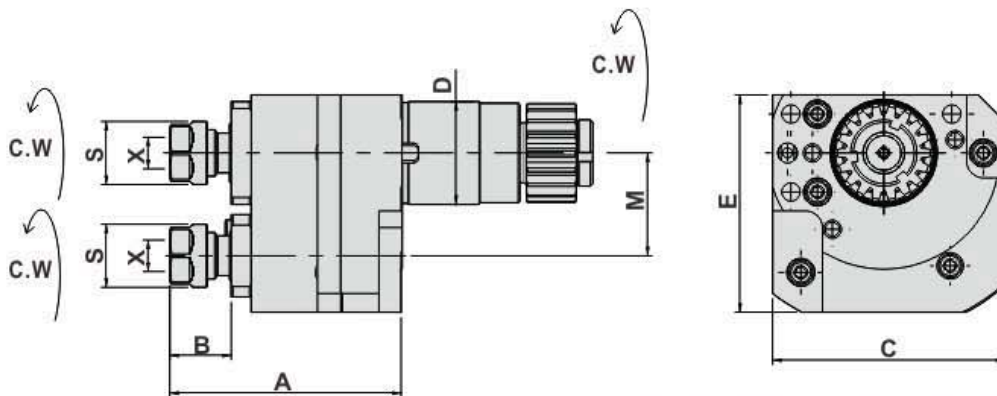

- To be used for collet DIN 6499
- Collet is not included

## DIMENSIONS

Models	D	X Capacity	S	Maximum R.P.M	A	B	C	E	M	Code No.	Order No.	(Kg) Weight
L20E (2M) /L32	31	1-7 ER11	19	4000	70	18.5	70	65.5	31	131609-000	GSC-1607	1.6



# MILLING AND DRILLING HEAD

Main Tool Post -Radius Machining

# GROMAX

TYPE

CITIZEN

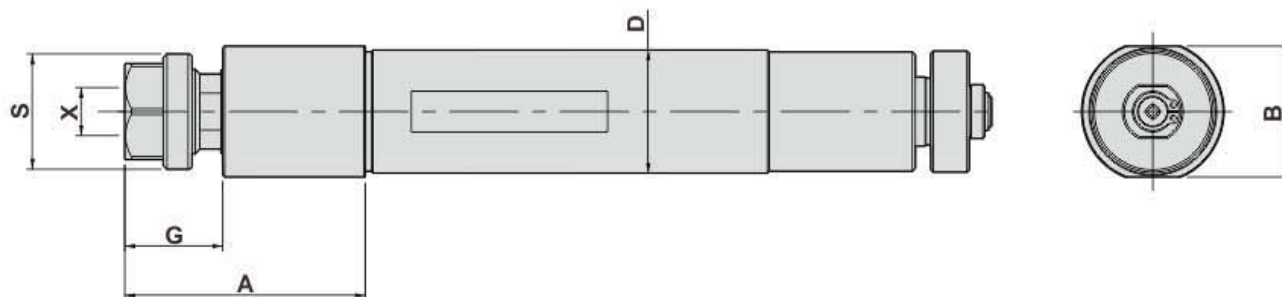

- To be used for collet DIN 6499
- Collet is not included

## DIMENSIONS

Models	D	X Capacity	S	Maximum R.P.M.	A	B	G	Code No.	Order No.	(Kg) Weight
L20E(1M)	32	1-10 ER16	30	6000	62	34	25	132603-000	GSC-1010	1.2

# DOUBLE BORING BAR HOLDER

Main Tool Post - End Surface Machining

# GROMAX

TYPE

CITIZEN

I

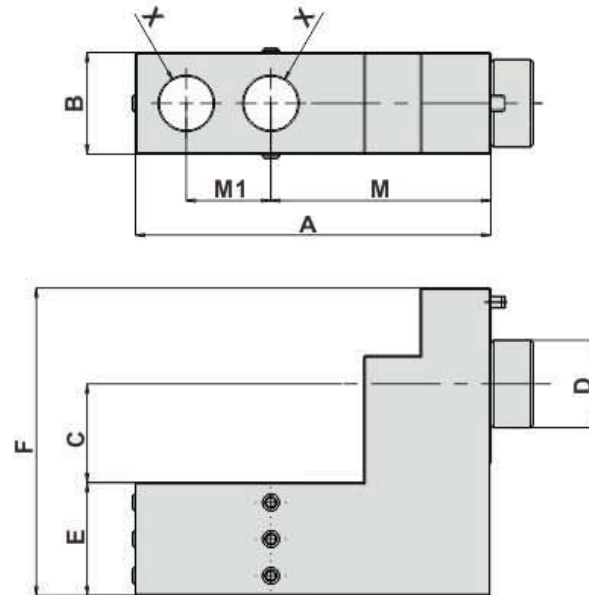

## DIMENSIONS

Models	D	X	A	B	C	E	F	M	M1	Code No.	Order No.	(Kg) Weight
L20E/7M9	31	0.75"(inch)	126	36	35	40	109	78	30	3E1108-000	GDF-508-B19.05x2	2.2

# DOUBLE BORING BAR HOLDER

Main Tool Post - End Surface Machining

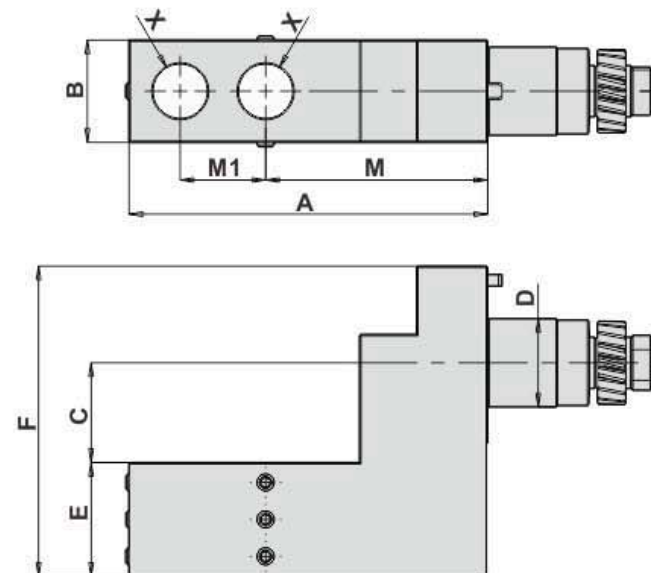

## DIMENSIONS

Models	D	X	A	B	C	E	F	M	M1	Code No.	Order No.	(Kg) Weight
L20E/7M9	31	0.75"(inch)	126	36	35	40	109	78	30	3E1110-000	GDF-509-B19.05x2	2.3

## TRIPLE BORING BAR HOLDER

Main Tool Post - End Surface Machining

TYPE

CITIZEN

H

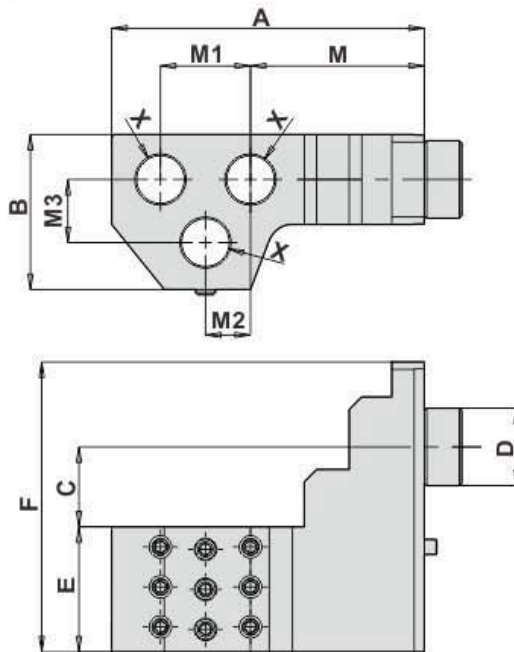

### DIMENSIONS

Models	D	X	A	B	C	E	F	M	M1	M2	M3	Code No.	Order No.	(Kg) Weight
L20E/7M9	31	0.75"(inch)	125	62	32	50	116	69.5	36	18	25.24	3E1109-000	GSE-3207-B19.05x3	2.7

## TRIPLE BORING BAR HOLDER

Main Tool Post - End Surface Machining

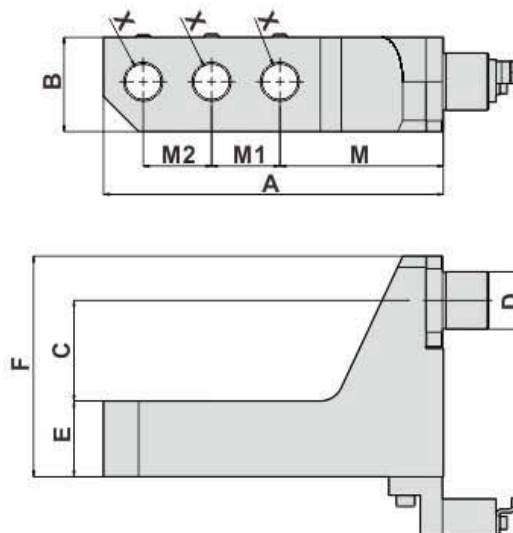

### DIMENSIONS

Models	D	X	A	B	C	E	F	M	M1/M2	Code No.	Order No.	(Kg) Weight
L20E(2M) /L32	31	0.75"(inch)	184	51	54.5	41	119.5	88.5	37	3E1119-000	GDF-3210	4.4

# TRIPLE BORING BAR HOLDER

Main Tool Post - End Surface Machining

# GROMAX

TYPE

CITIZEN

I

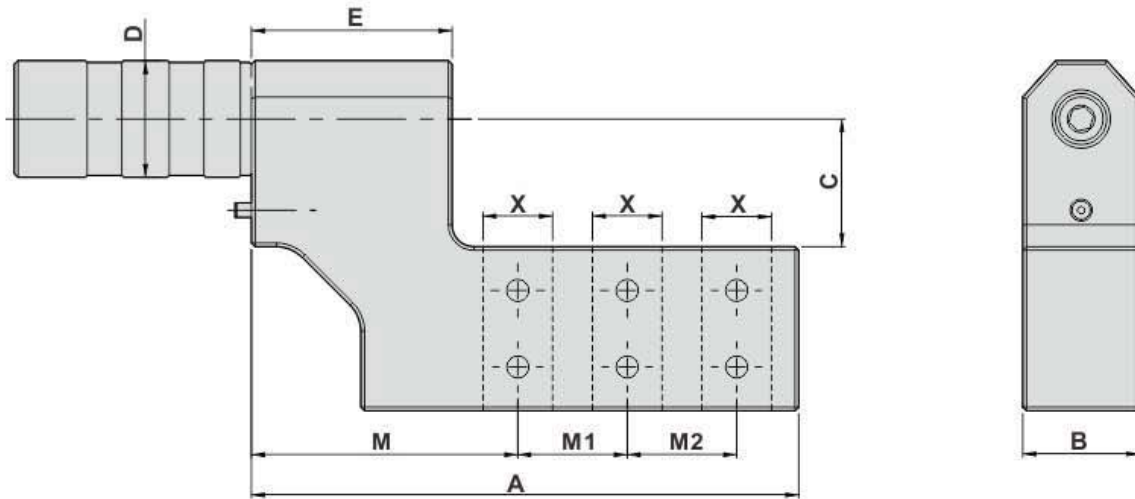

## DIMENSIONS

Models	D	X	A	B	C	E	M	M1	M2	Code No.	Order No.	(Kg) Weight
L20E/7M9	32	0.75"(inch)	150	32	35	55	73	30	30	3E1107-000	GDF-703-19.05x3	2.3

## TURNING HOLDER

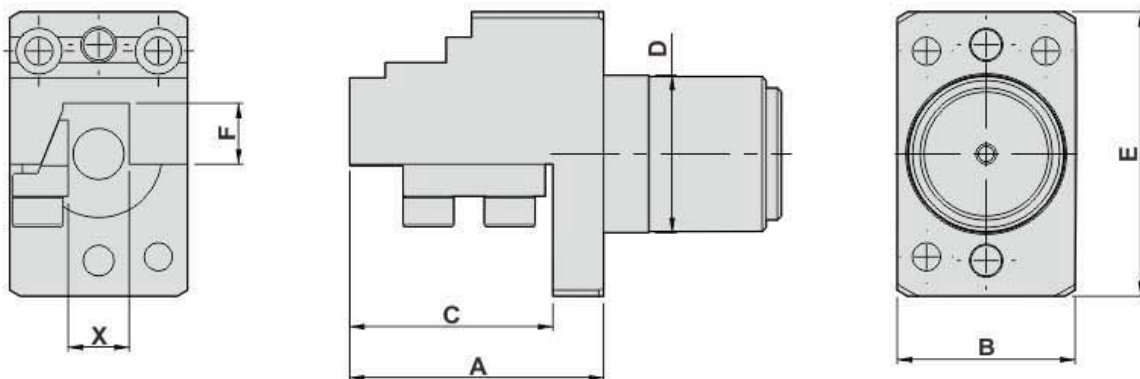

## DIMENSIONS

● External coolant supply

Models	D	X	A	B	C	E	F	Code No.	Order No.	(Kg) Weight
L20E(2M) /L32	25	12	50	35	40	56	12	403102-000	GTF6312	0.5



# MILLING AND DRILLING HEAD

Main Tool Post - End Surface Machining

# GROMAX

TYPE

CITIZEN

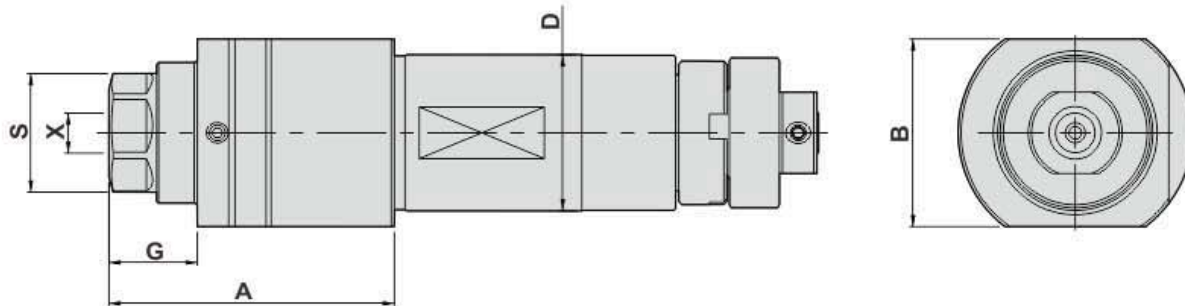

- To be used for collet DIN 6499
- Collet is not included

## DIMENSIONS

Models	D	X Capacity	S	Maximum R.P.M.	A	B	G	Code No.	Order No.	(Kg) Weight
L20	25	1-7 ER11	19	6000	45.5	30	14	125601-000	GSE-307	0.5

# MILLING AND DRILLING HEAD OFFSET

Main Tool Post - Radius Machining

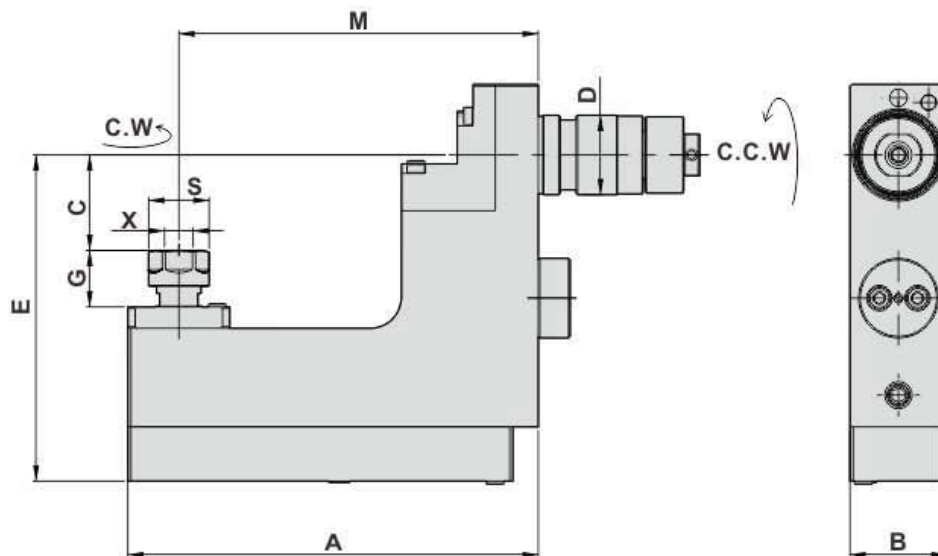

- To be used for collet DIN 6499
- Collet is not included

## DIMENSIONS

Models	D	X Capacity	S	Maximum R.P.M.	A	B	C	E	G	M	Code No.	Order No.	(Kg) Weight
L20XII	25	1-7 ER11	19	4000	129	30.5	30	102.5	17.8	113	225607-000	GSC-1407	2.2

# MILLING AND DRILLING HEAD MULTI HEADS-OFFSET

Main Tool Post - End Surface Machining

# GROMAX

TYPE CITIZEN

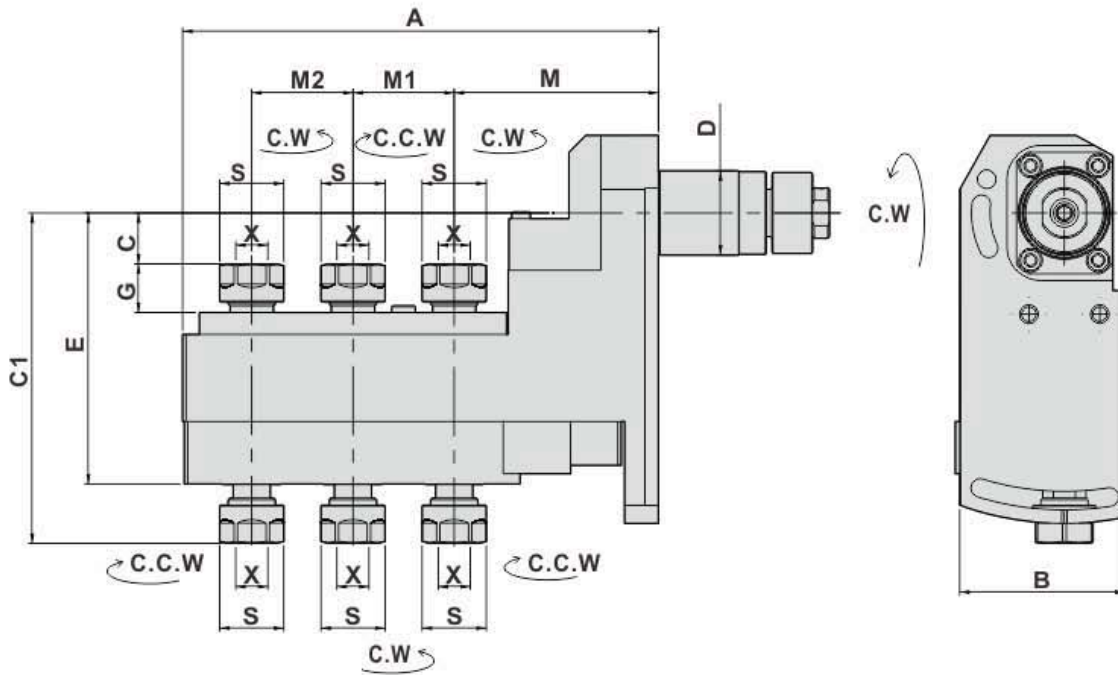

- To be used for collet DIN 6499
- Collet is not included

## DIMENSIONS

Models	D	X Capacity	S	Maximum R.P.M	A	B	C	C1	E	G	M	M1/M2	Code No.	Order No.	(Kg) Weight
L20	25	1-7 ER11	19	4000	141	49	15.1	97.9	80.3	14.4	60.5	30	225604-000	GSE-3607	2.9

# MILLING AND DRILLING HEAD OFFSET

Sub Tool Post - End Surface Machining

# GROMAX

TYPE

CITIZEN

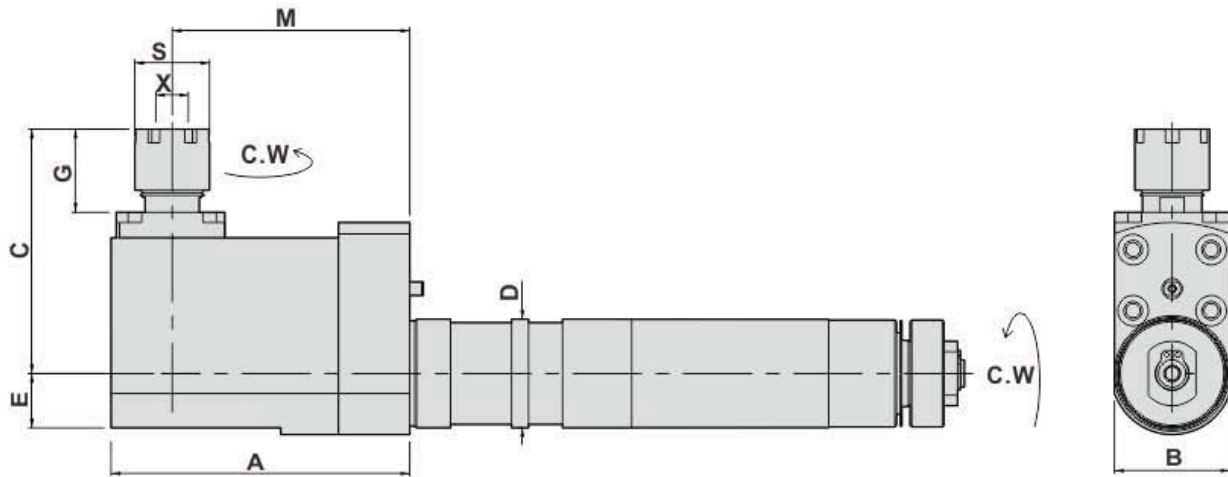

## DIMENSIONS

- To be used for collet DIN 6499
- Collet is not included

Models	D	X Capacity	S	Maximum R.P.M.	A	B	C	E	G	M	Code No.	Order No.	(Kg) Weight
L20	32	1-10 ER16M	22	4000	88	35	74.5	16	27	70	232605-000	GSE-107	2

# MILLING AND DRILLING HEAD OFFSET

Main Tool Post - End Surface Machining

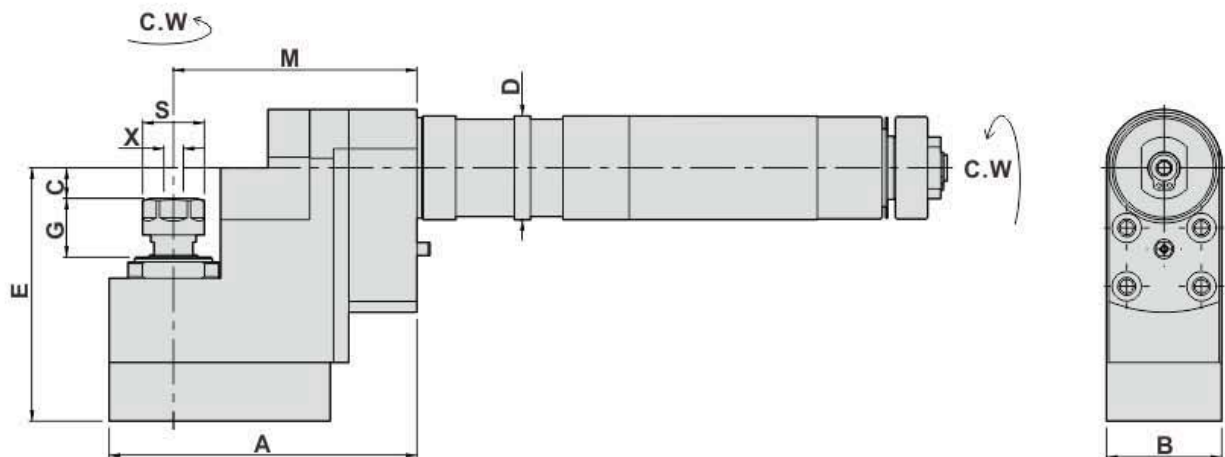

## DIMENSIONS

- To be used for collet DIN 6499
- Collet is not included

Models	D	X Capacity	S	Maximum R.P.M.	A	B	C	E	G	M	Code No.	Order No.	(Kg) Weight
L20	32	1-7 ER11	19	4000	95	35.5	9.5	78	20	75	232604-000	GSE-607	2.3

## MILLING AND DRILLING HEAD DOUBLE HEADS-OFFSET

Main Tool Post - End Surface Machining

TYPE CITIZEN

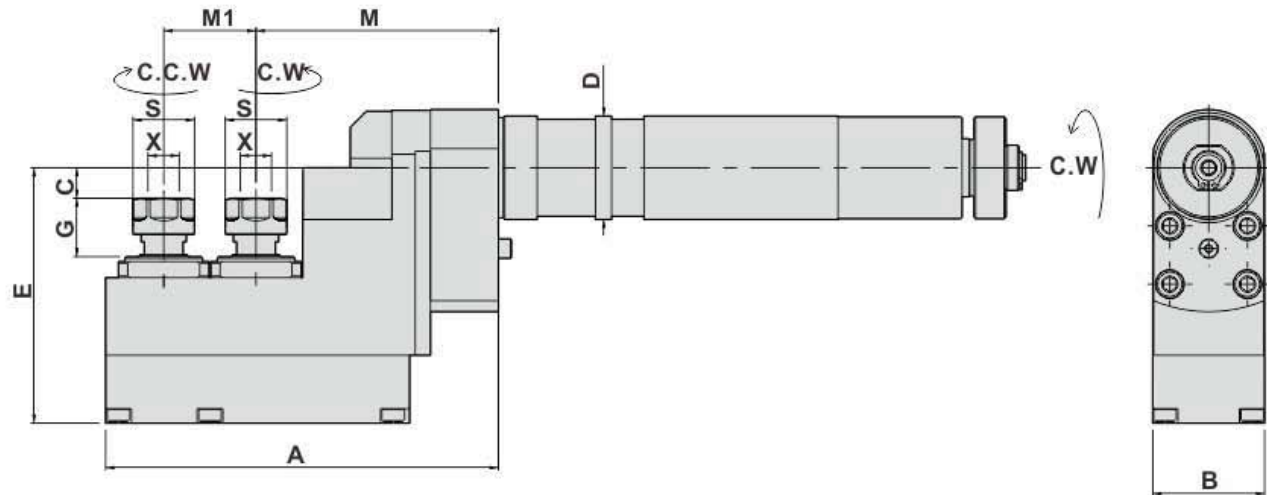

- To be used for collet DIN 6499
- Collet is not included

### DIMENSIONS

Models	D	X Capacity	S	Maximum R.P.M.	A	B	C	E	G	M	M1	Code No.	Order No.	(Kg) Weight
L20	32	1-7 ER11	19	4000	122	35	9.4	79	18	75	28.6	232607-000	GSE-1072	2.7



# TRIPLE BORING BAR HOLDER

Main Tool Post - End Surface Machining



TYPE

CITIZEN

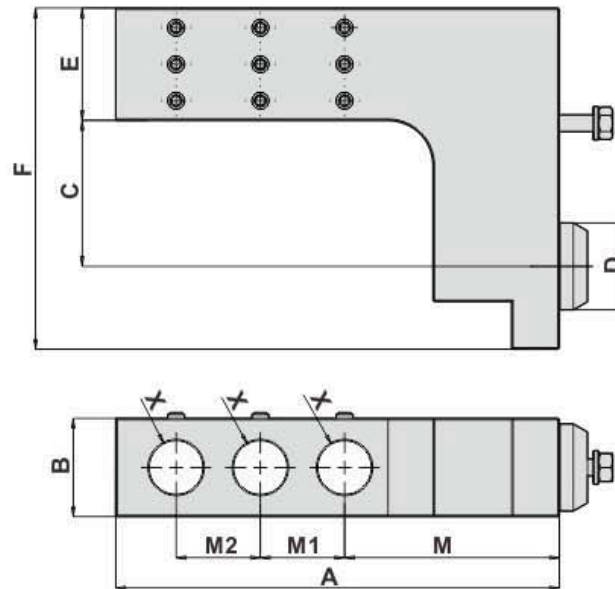

## DIMENSIONS

Models	D	X	A	B	C	E	F	M	M1/M2	Code No.	Order No.	(Kg) Weight
L20/32	31	0.75"(inch)	158	35	52	40	121.5	76.5	30	3E1118-000	GDF-1207-B19.05x3	2.4

# BORING BAR HOLDER

Main Tool Post - End Surface Machining

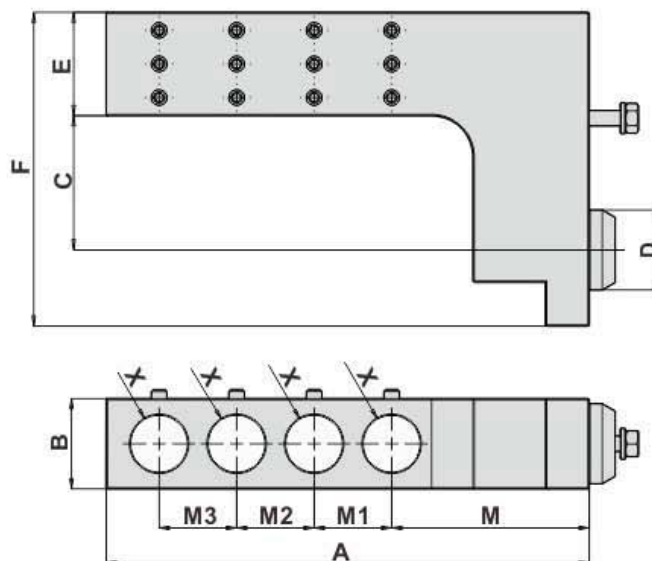

## DIMENSIONS

Models	D	X	A	B	C	E	F	M	M1/M2/M3	Code No.	Order No.	(Kg) Weight
L20/32	31	22	187	35	52	40	121.5	76.5	30	322101-000	GDF-1207-B22x4	2.5

# TRIPLE BORING BAR HOLDER

Main Tool Post - End Surface Machining

# GROMAX

TYPE

CITIZEN

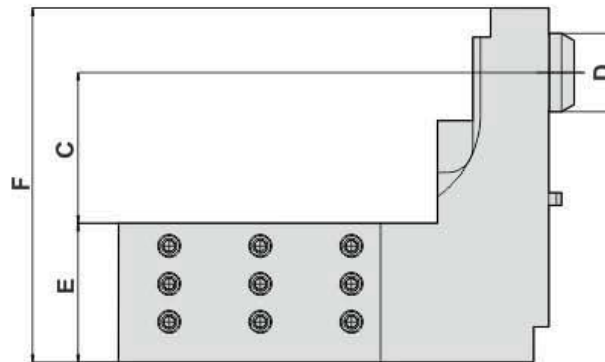
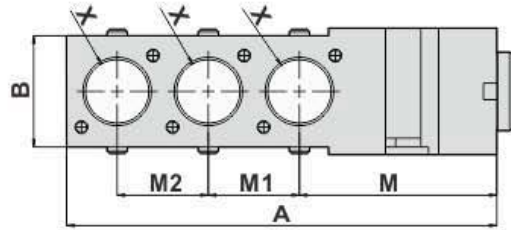

## DIMENSIONS

Models	D	X	A	B	C	E	F	M	M1/M2	Code No.	Order No.	(Kg) Weight
L20/32	31	25	170	44	59.5	55	140	78	36	306105-000	GDF-1601-B25x3	4
L20/32	31	1"(inch)	170	44	59.5	55	140	78	36	3F1111-000	GDF-1601-B25.4x3	4

# BORING BAR HOLDER

Main Tool Post - End Surface Machining

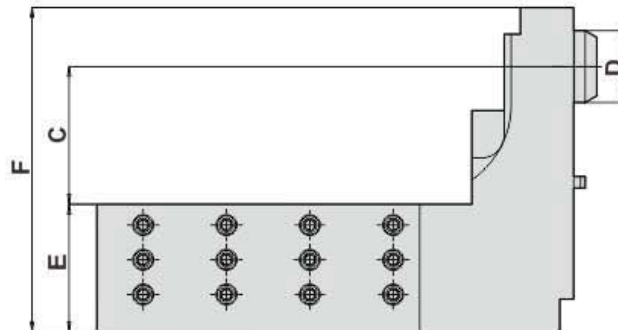
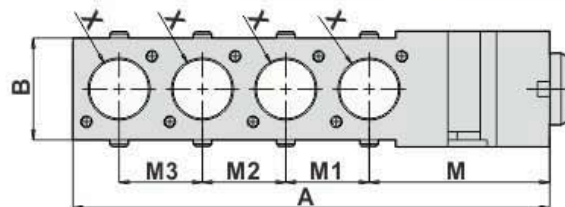

## DIMENSIONS

Models	D	X	A	B	C	E	F	M	M1/M2/M3	Code No.	Order No.	(Kg) Weight
L20/32	31	1"(inch)	206	44	59.5	55	140	78	36	3F1112-000	GDF-1601-B25.4x4	4.4

# BORING BAR HOLDER

# GROMAX

TYPE CITIZEN

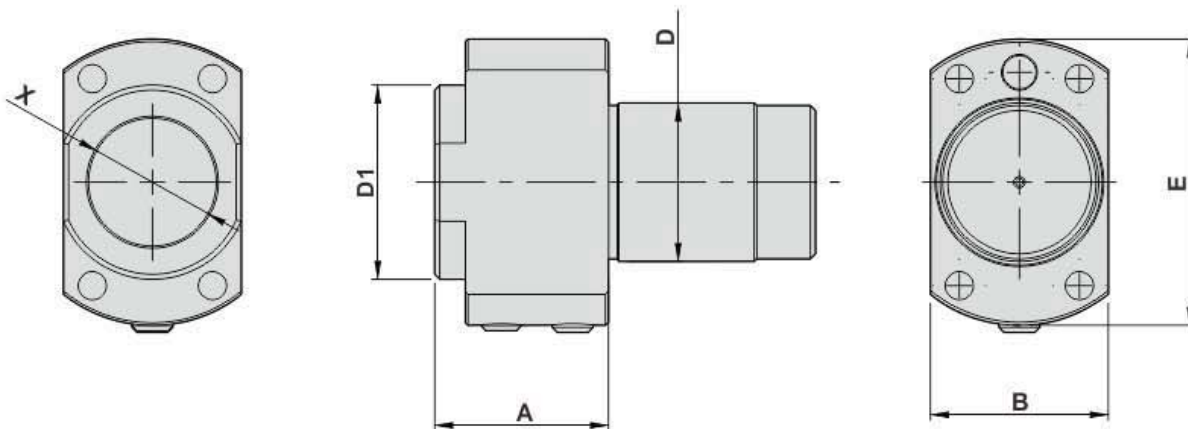

- External coolant supply
- Internal coolant supply

## DIMENSIONS

Models	D	X Capacity	A	B	D	D1	E	Code No.	Order No.	(Kg) Weight
L20/L32/A32	31	25	34	34.8	31	38	56	306104-000	SAU-825-B25	0.4
L20/L32/A32	31	1"(inch)	34	34.8	31	38	56	3F1107-000	L20-SAU-825-B25.4	0.4

# MILLING AND DRILLING HEAD OFFSET

Main Tool Post - End Surface Machining

# GROMAX

TYPE

CITIZEN

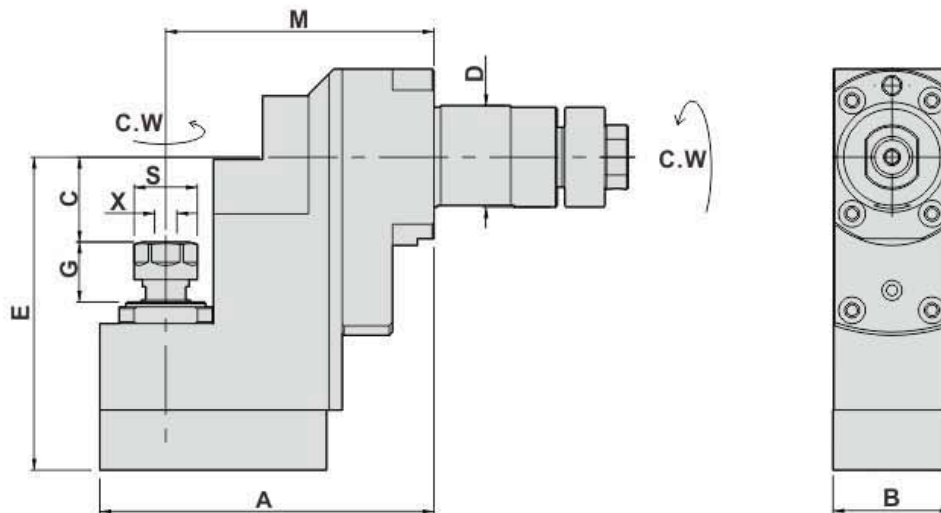

## DIMENSIONS

- To be used for collet DIN 6499
- Collet is not included

Models	D	X Capacity	S	Maximum R.P.M.	A	B	C	E	G	M	Code No.	Order No.	(Kg) Weight
A20/2F7	31	1-7 ER11	19	5000	100	35.5	25.5	94	19.5	80.6	231611-000	BSE-107	2.3

# MILLING AND DRILLING HEAD DOUBLE HEADS-OFFSET

Main Tool Post - End Surface Machining

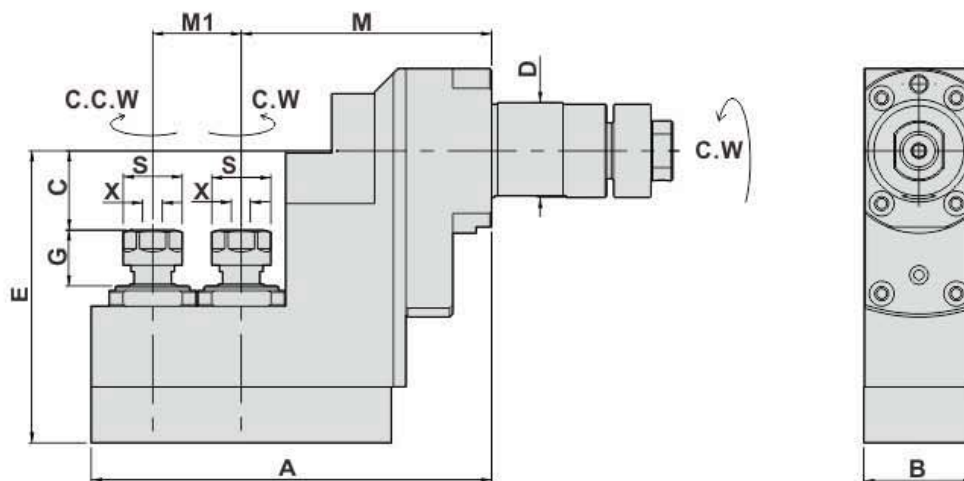

## DIMENSIONS

- To be used for collet DIN 6499
- Collet is not included

Models	D	X Capacity	S	Maximum R.P.M.	A	B	C	E	G	M	M1	Code No.	Order No.	(Kg) Weight
A20/2F7	31	1-7 ER11	19	4000	129	35.5	25.5	94	19.5	80.6	28.5	231612-000	BSE-207	2.6



## MILLING AND DRILLING HEAD TRIPLE HEADS-OFFSET

Main Tool Post - End Surface Machining

TYPE CITIZEN

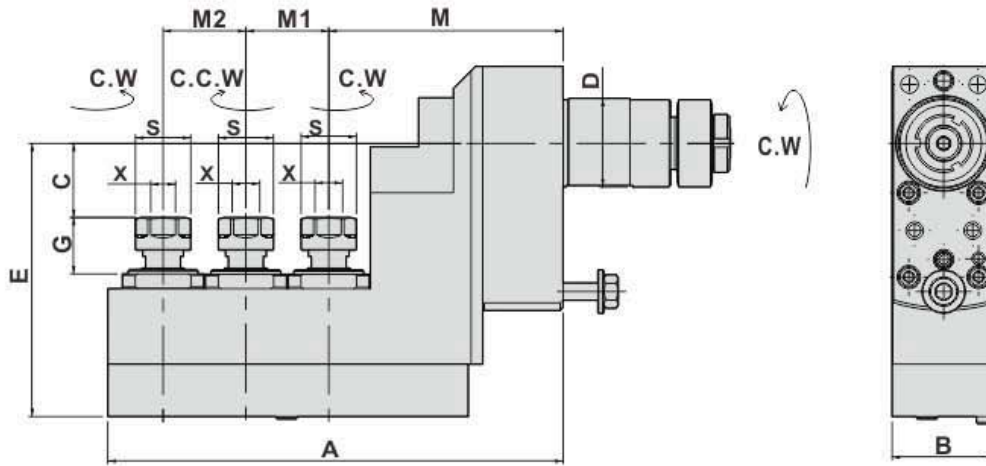

### DIMENSIONS

- To be used for collet DIN 6499
- Collet is not included

Models	D	X Capacity	S	Maximum R.P.M	A	B	C	E	G	M	M1	M2	Code No.	Order No.	(Kg) Weight
A20/2F7	31	1-7 ER11	19	4000	157	35.5	25.5	94	19.5	80.6	28.5	28.5	231613-000	BSE-307	3

## MILLING AND DRILLING HEAD MULTI HEADS-OFFSET

Main Tool Post - End Surface Machining

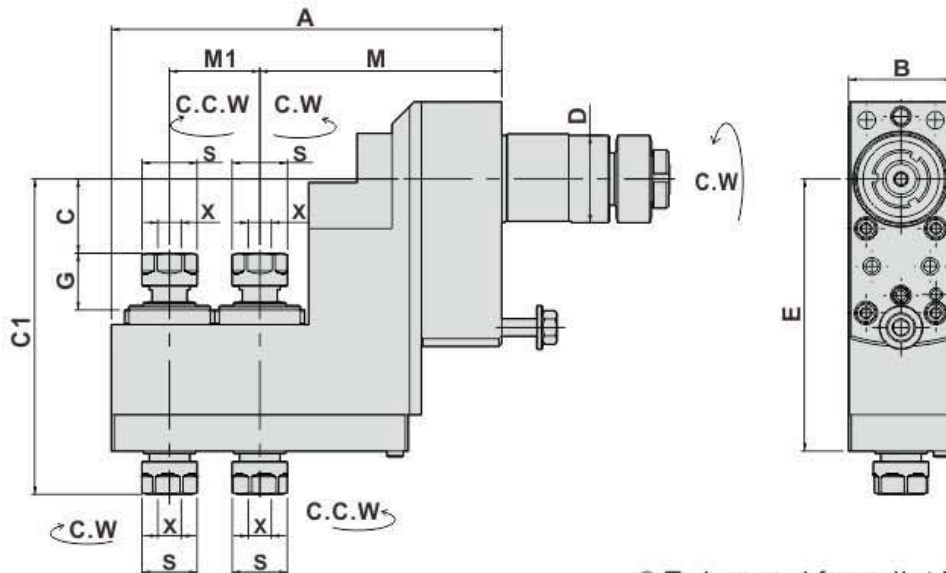

### DIMENSIONS

- To be used for collet DIN 6499
- Collet is not included

Models	D	X Capacity	S	Maximum R.P.M	A	B	C	C1	E	G	M	M1	Code No.	Order No.	(Kg) Weight
A20/2F7	31	1-7 ER11	19	4000	134	36	25.5	108	93.5	18.8	83.1	31	231614-000	BSE-407	2.7

## MILLING AND DRILLING HEAD

Sub Tool Post - End Surface Machining

TYPE

CITIZEN

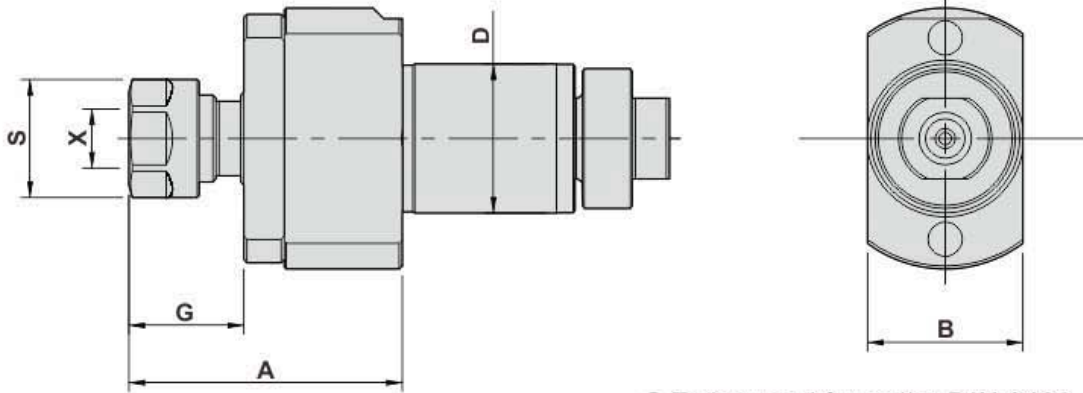

- To be used for collet DIN 6499
- Collet is not included

### DIMENSIONS

Models	D	X Capacity	S	Maximum R.P.M.	A	B	G	Code No.	Order No.	(Kg) Weight
K12/16E	24	1-7 ER11	19	4000	44	25	18.5	124602-000	GSC-807	0.3

## MILLING AND DRILLING HEAD MULTI HEADS-OFFSET

Main Tool Post - End Surface Machining

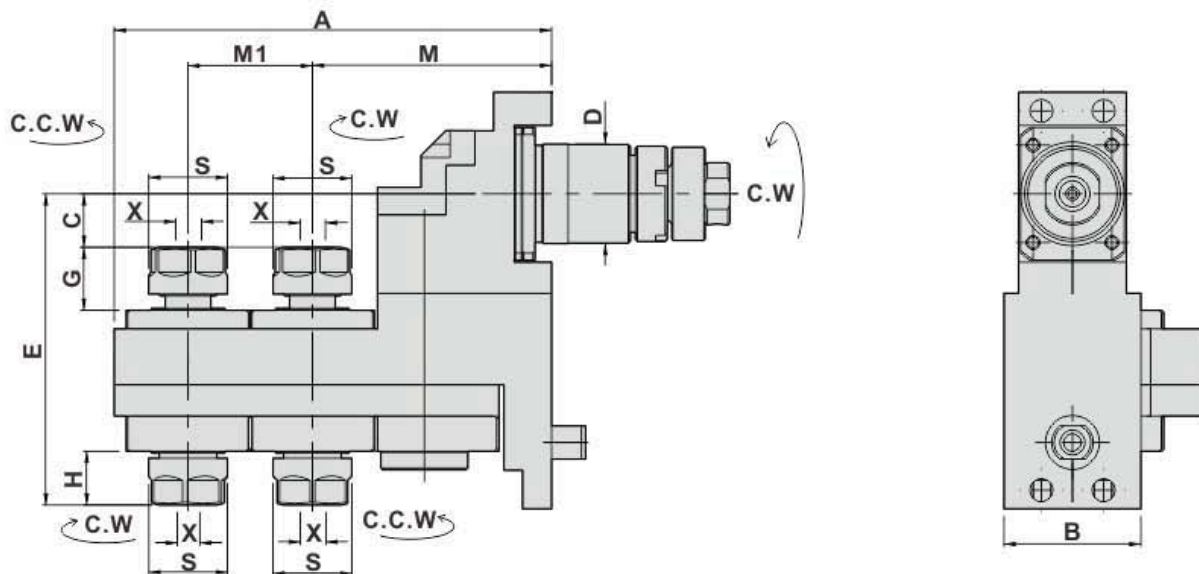

- To be used for collet DIN 6499
- Collet is not included

### DIMENSIONS

Models	D	X Capacity	S	Maximum R.P.M.	A	B	C	E	G	H	M	M1	Code No.	Order No.	(Kg) Weight
K12/16E	24	1-7 ER11	19	4000	104	33	13	75	15	13	57.7	30	224601-000	GSE-2007	1.3

## DOUBLE BORING BAR HOLDER

Main Tool Post - End Surface Machining

TYPE CITIZEN

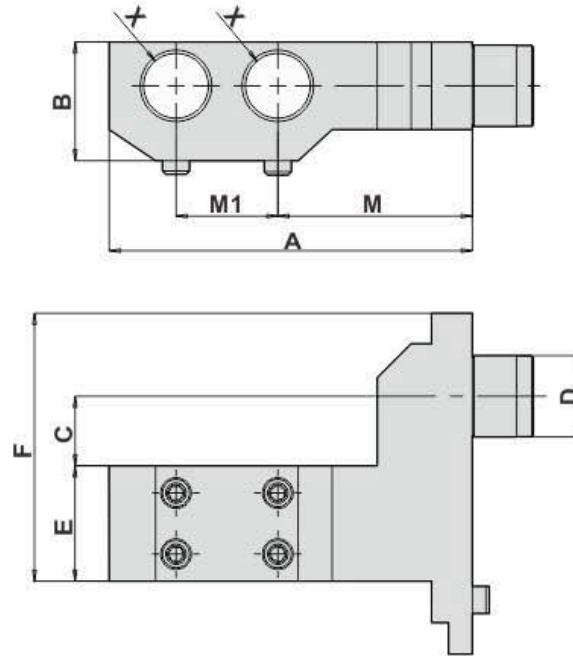

### DIMENSIONS

Models	D	X	A	B	C	E	F	M	M1	Code No.	Order No.	(Kg) Weight
K12/16E	24	0.75"(inch)	107	35	20.5	34	79	57.3	30	3E1111-000	BDF-103-B19.05x2	1.2
K12/16E	24	20	107	35	20.5	34	79	57.3	30	305101-000	BDF-103-B20x2	1.2

## DOUBLE BORING BAR HOLDER

Main Tool Post - End Surface Machining

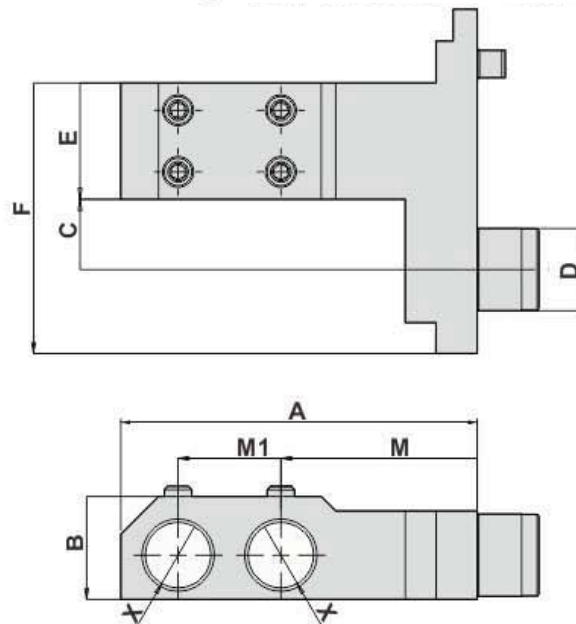

### DIMENSIONS

Models	D	X	A	B	C	E	F	M	M1	Code No.	Order No.	(Kg) Weight
K12/16E	24	0.75"(inch)	104	30	20.5	34	79	57.3	30	3E1112-000	BDF-103-T3	1